

opal contracts
innovative elegant dependable

Olympian 1200
vertical system



Olympian 1200

vertical system



Application

The Opal Olympian System 1200 vertical blind offers a solution to the commercial sector which requires little maintenance and will consistently give an elegant look to any room or area. Vertical blinds can be installed to the majority of windows and all are manufactured to customer's requirements. The Olympian range is available with 89mm or 127mm louvres to compliment the window size and in a vast selection of fabrics with straight, curved or twin-track headrails. All of our vertical blinds are manufactured with aluminium components and metal chains which ensure durability throughout the lifetime of the blinds.

Control

Opal Olympian vertical blinds are available with a number of control methods including chain and cord operation, wand, crank, motorised and twin-track.

Motorised blinds including remote control, switch control, infra-red control and automated options are available with solar detectors and timers for controlling blinds in groups or centrally.

Fabrics

As with all other blinds within the Olympian range, all fabrics are fire retardant to BS5867:Part 2 Type B and are available with a wide range of properties including dim-out, black-out, solar protection and wipe-able. Anti-bacterial properties are also available on certain fabric ranges.

The majority of our fabrics can be sponge cleaned and some are washable.

Our Olympian range of fabrics endeavours to suit the majority of schemes but should the need arise for a particular fabric Opal will endeavour to source from it's wide range of quality suppliers.

Safety Features

All blinds within the Olympian range come with child safety features as standard. Sewn in bottom weights and removable cranks are also available as options.

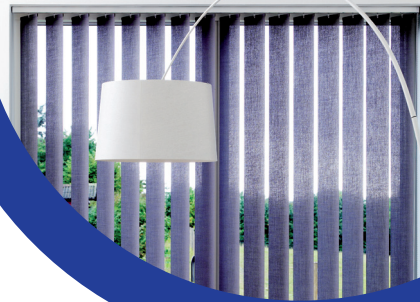

1210

Chain operated vertical blinds with white aluminium headrail and metal operating chain, louvre weights and white linking chains.



1220

Wand operated vertical blinds with white aluminium headrail and metal operating chain, louvre weights and white linking chains.



1240

Motorised vertical blinds with options for infrared, remote control and automated controls. White aluminium headrail and metal operating chain, louvre weights and white linking chains.



1250

Twin white aluminium headrails with metal operating chain, louvre weights and white linking chain. Louvres are fixed between both headrails and suitable where the louvres need to remain rigid, e.g. sloping windows.



1260

Mono controlled chain operated vertical blind enables the louvres to be traversed and tilted simply and safely by means of a continuous chain loop.

Olympian 1200 vertical system

Specifications

Louvre Size	Minimum Width	Maximum Width	Minimum Drop	Maximum Drop
89mm	250mm	5000mm	200mm	5000mm
127mm	250mm	6000mm	200mm	4000mm
Profile	White as standard, colour as cost option			
Brackets	Face fix or top fix brackets			
Control	Chain	Wand	Motorised	Mono Gear
Fabrics	Wide choice of fabrics available in dim-out, black-out, solar protection and anti-bacterial protection. Please ask for sample swatches or see the full range at www.opalcontracts.co.uk			

TYPE	
Operation	System
Chain	1210
Spring Assist	1220
Motor	1240
Twin Track	1250
Mono Command	1260
Fascia*	F
Coupled*	C

*Suffix System code as required

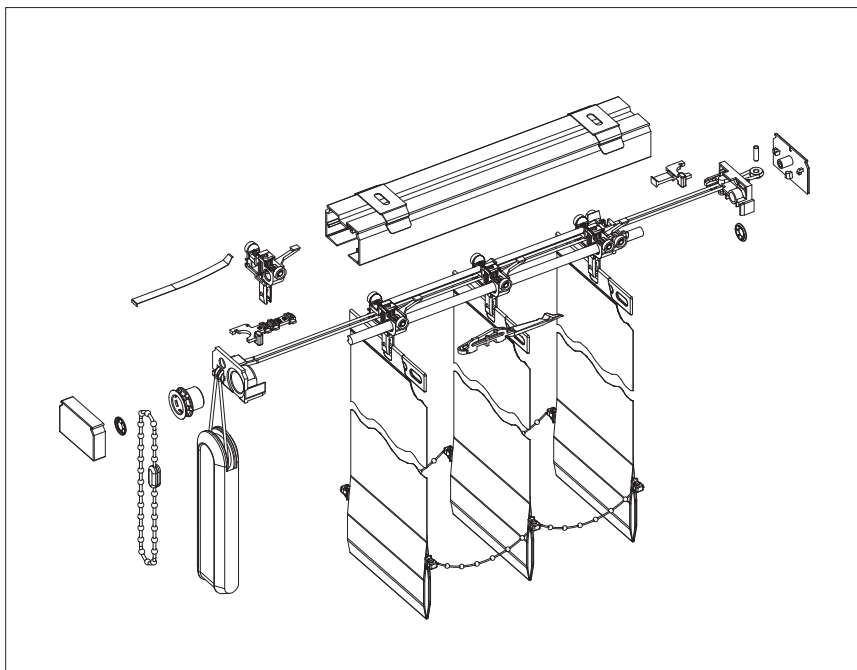

Maintenance

Periodically check all fittings are secure.
Lubricate moving parts where necessary.
Ultra-sonic cleaning service available.
Please ask for details.

Opal Contracts (UK) Limited
Units 2-4 Cato Street North,
Nechells, Birmingham,
B7 4TE
t: 0121 333 5507
f: 0121 359 7648
info@opalcontracts.co.uk
www.opalcontracts.co.uk